

# Air-operated Hydraulic Pressure Jack

## AJ-25T2

- Application: apply to fast lifting jobs of lightweight truck/passenger car.
- Feature: lifting in fast speed, stable function, convenient usage.

### Technique Parameter

Jacking Capacity:25T/10T
Air Pressure:0.62-0.9mpa
Lowest Height:180mm
Hoisting Height:25T: 92mm 10T: 195mm
Extension Height:45mm 100mm
Rated Pressure:32MPa
N.W.:57kg

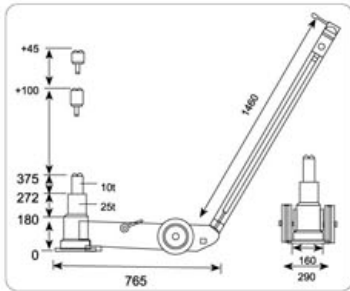

Item No.	Model No.	Commodity
12375	AJ-25T2	Air-operated Hydraulic Pressure Jack



## AJ-50T2

- Application: apply to fast lifting jobs of heavy duty truck.
- Feature: lifting in fast speed, stable function, convenient usage.

### Technique Parameter

Jacking Capacity:50T/25T
Air Pressure:0.62-0.9mpa
Lowest Height:230mm
Hoisting Height:50T: 117mm 25T: 225mm
Extension Height:45mm 100mm
Rated Pressure:32Mpa
N.W.:80kg

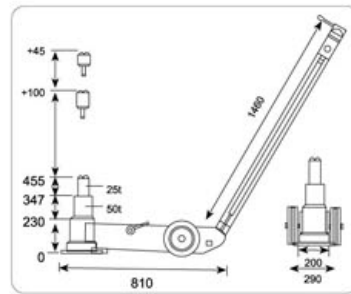

Item No.	Model No.	Commodity
12380	AJ-50T2	Air-operated Hydraulic Pressure Jack

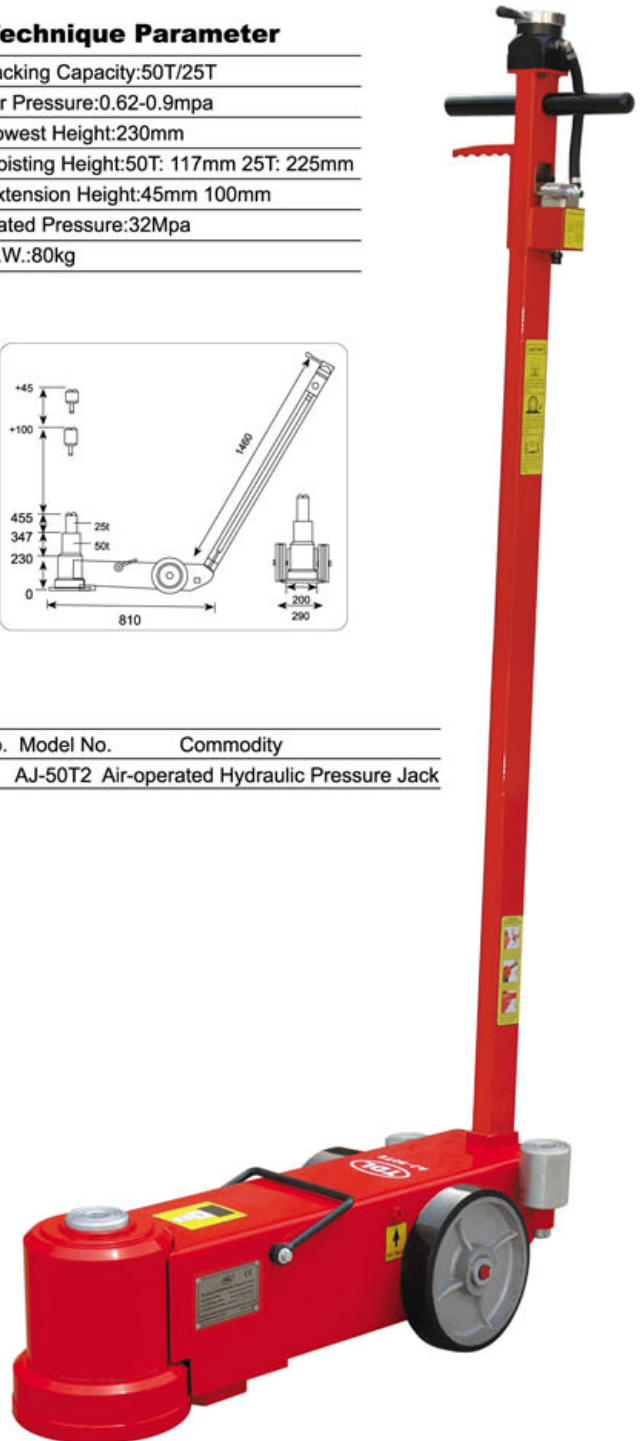

# Air-operated Hydraulic Pressure Jack

## AJ-75T2

- Application: apply to fast lifting jobs of heavy duty truck.
- Feature: lifting in fast speed, stable function, convenient usage.

### Technique Parameter

Jacking Capacity:75T/40T
Air Pressure:0.62-0.9mpa
Lowest Height:210mm
Hoisting Height:75T: 97mm 40T: 200mm
Extension Height:20mm 70mm 100mm
Rated Pressure:32Mpa
N.W.:88kg

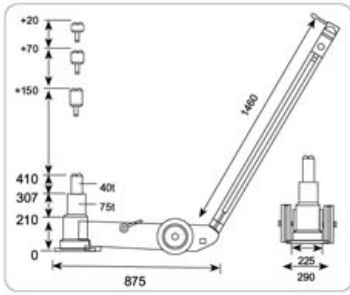

Item No.	Model No.	Commodity
12392	AJ-75T2	Air-operated Hydraulic Pressure Jack



## AJ-100T2

- Application: apply to fast lifting jobs of engineering mechanism or heavy-facility
- Feature: lifting in fast speed, stable function, convenient usage

### Technique Parameter

Jacking Capacity:100T/60T
Air Pressure:0.62-0.9mpa
Lowest Height:220mm
Hoisting Height:100T: 90mm 60T: 170mm
Extension Height:20mm 70mm 100mm
Rated Pressure:32Mpa
N.W.:108kg

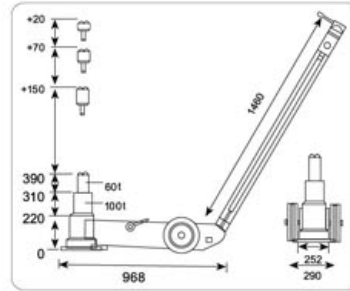

Item No.	Model No.	Commodity
12398	AJ-100T2	Air-operated Hydraulic Pressure Jack

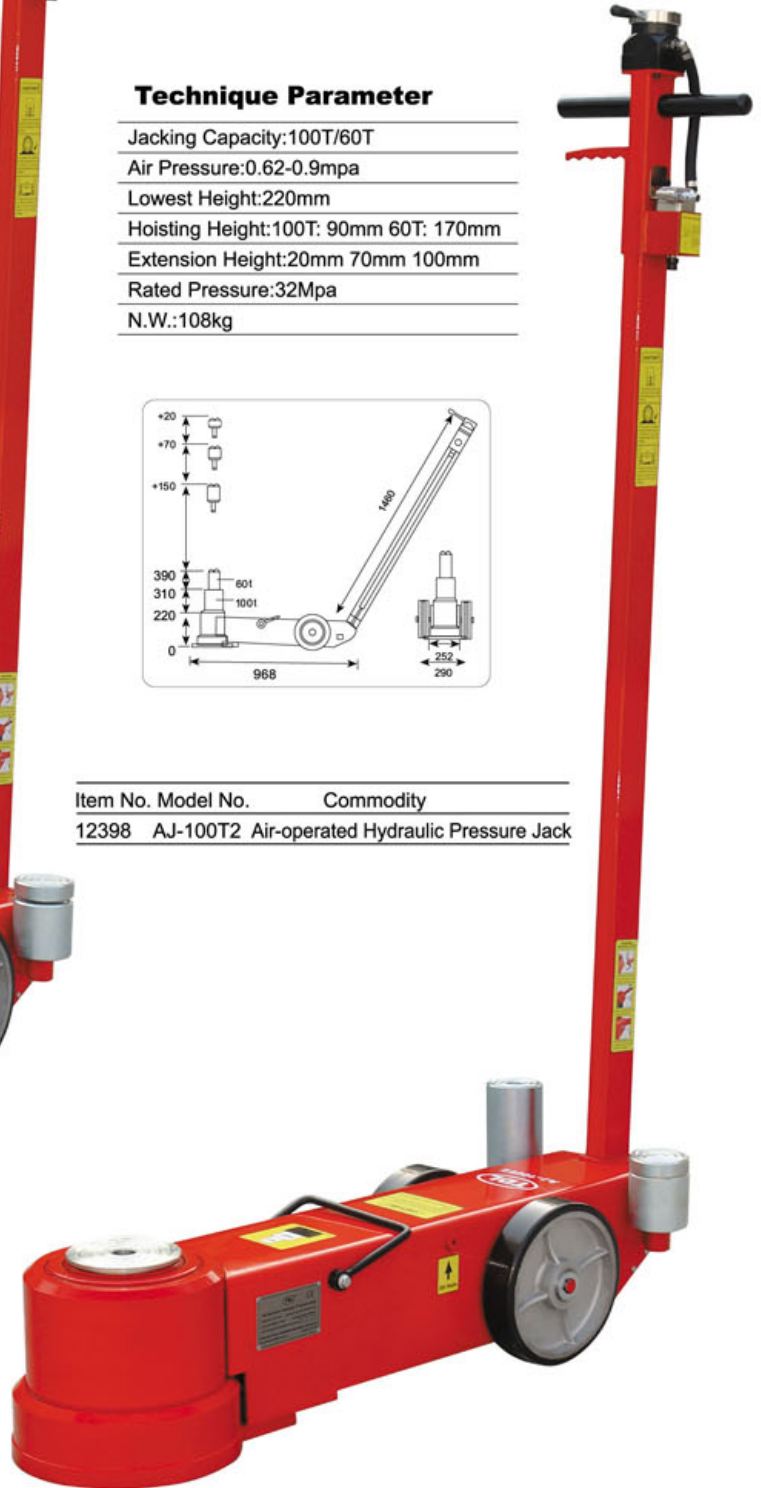

# Air-operated Hydraulic Pressure Jack

## AJ-50T3

- Application: apply to fast lifting jobs of bus
- Feature: lifting in fast speed, stable function, convenient usage

### Technique Parameter

Jacking Capacity:50T/25T/10T
Air Pressure:0.62-0.9mpa
Lowest Height:160mm
Hoisting Height:50T: 60mm 25T: 113mm 10T: 182mm
Extension Height:45mm 100mm
Rated Pressure:32Mpa
N.W.:70kg

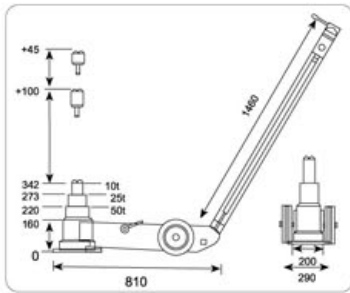

Item No.	Model No.	Commodity
12385	AJ-50T3	Air-operated Hydraulic Pressure Jack



## AJ-75T3

- Application: apply to fast lifting jobs of bus
- Feature: lifting in fast speed, stable function, convenient usage

### Technique Parameter

Jacking Capacity:75T/40T/20T
Air Pressure:0.62-0.9mpa
Lowest Height:175mm
Hoisting Height:75T: 67mm 40T: 130mm 20T: 200mm
Extension Height:20mm 70mm 100mm
Rated Pressure:32Mpa
N.W.:80kg

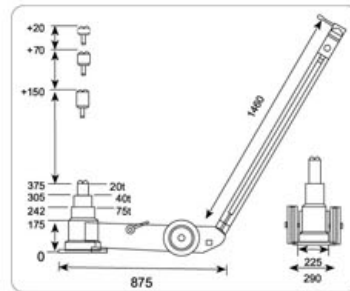

Item No.	Model No.	Commodity
12393	AJ-75T3	Air-operated Hydraulic Pressure Jack



# Truck/Passenger Tire Changing Tool

- Mount all tubeless tires range from 17.5" to 24.5" .Demount tire in 8 seconds, and remount in 20 seconds without strain.Demounting truck tires with TD-100M so easily and won't damage beads.Two simple tools can do it all. Work on standard and super luxury beads.



12320



12321

Item No.	Model No.	Commodity	Weight
12320	TD-100M	Truck/Passenger Tubeless Tire Demount Tool	13kg
12321	TD-200M	Truck/Passenger Tubeless Tire Mount Tool	6kg

- TD-300M is improved model of TD-100M, applying to demount tubeless tire with super wide tire tread. It is ideal for demounting 445×225 tires and shows much more humanity design.



12322



12321

Item No.	Model No.	Commodity	Weight
12322	TD-300M	Truck/Passenger Tubeless Tire Demount Tool	13kg
12321	TD-200M	Truck/Passenger Tubeless Tire Mount Tool	6kg

- The left of 55M is used for changing truck/passenger tubeless tires, and the right of it is used for demounting truck/passenger tube type.Use in pairs when demounting tires.Made from special material, with anti-fatigue and not easy to break.



12311



12306



12301

Item No.	Model No.	Commodity	Length	Weight
12311	TD-55M	Truck/Passenger Tubeless Tire Changing Tool	105cm	6kg
12306	TD-38M	Truck/Passenger Tubeless Tire Changing Tool	94cm	5kg
12301	TD-25M	Truck /Passenger Tire Changing Tool	85cm	5kg

# Iron Bead Seater & Tire Cream

- Loosen beads with bead-breaking foot and ram bar, but never cut the bead of the tire. The wedge foot is forced between the bead and rim flange. No other bead breaking tools are necessary. Designed with an exclusive spring action to reduce user fatigue associated with slide hammer kickback



Item No.	Model No.	Commodity	Weight
12325	TD-30B	Bead Breaker	13kg

- After mounting tire, simply apply a blast from Bead Seater between the tire and rim to seat the toughest beads quickly and easily. With overpressure automatic pop-off valve system.



Item No.	Model No.	Commodity	Cubage	Weight
12350	CH-5	Iron Bead Seater	0.02m <sup>3</sup>	13kg

- Prevent the tire bead from slipping when mounting the top bead. Effectual to enhance working efficiency.



Item No.	Commodity	Weight
12330	Bead Keeper	1kg

## C2 Tire Cream

- Apply to lubricate the passenger car tire and rim in order to avoid damaging the tire and rim when changing.



60129



60126



60121



60127



60122



60125

## P2 Tire Cream

- Apply to lubricate the truck or bus tire and rim in order to avoid damaging the tire and rim when changing.

Item No.	Model No.	Commodity	Weight
60126	C2	Tire Cream	1kg/bucket
60127	C2	Tire Cream	2kg/bucket
60129	C2	Tire Cream	4kg/bucket

Item No.	Model No.	Commodity	Weight
60121	P2	Tire Cream	1kg/bucket
60122	P2	Tire Cream	2kg/bucket
60125	P2	Tire Cream	4kg/bucket

## Air Operated Tire Spreader (With Stand)

- The Air Operated Tire Spreader (With Stand) is designed for tire fix and spread when repair the passenger tires. Available operation for inspecting, cutting, buffing, dust suctioning, inserting tubes and patching. The wider platform offers a more stable work surface. Adjustable light for increased visibility inside the tire. All makes the repair work more quickly and convenient.



Grease Filter



### Technique Parameter

Apply To	145-275
Voltage	220V/50Hz
Air Pressure Scope	8-10kg/cm <sup>2</sup>
Net Weight	62kg
Gross Weight	68kg
Appearance Color	Dark Red
Package Size	60cm×60cm×104cm

Item No.	Model No.	Commodity	Quantity
15706	BT-60CA	Air Operated Tire Spreader(With Stand)	1 Set

- The Air Operated Tire Spreader (With Lying) is designed for tire fix, spread and lift when repair the truck tires. Available operation for inspecting, cutting, buffing, dust suctioning, inserting tubes and patching. The wider platform offers a more stable work surface. Adjustable light can increase visibility inside the tire. All makes the repair work more quickly and convenient.



Grease Filter



### Technique Parameter

Apply To	8.25-20/14.00-20(9R--16.5R)
Voltage	220V/50Hz
Air Pressure Scope	8-10kg/cm <sup>2</sup>
Net Weight	134kg
Gross Weight	168kg
Appearance Color	Dark Red
Package Size	122cm×81cm×97cm

Item No.	Model No.	Commodity	Quantity
15708	BT-65C	Air Operated Tire Spreader(With Lying)	1 Set

# Air Operated Passenger Tire Vulcanizer

- The Air Operated Passenger Tire Vulcanizer designed for the heat vulcanization of the repaired of passenger car 145-275. The function of the vulcanizer: thermostatically controlled, timer and pneumatic pressure device. Including tread, shoulder, and sidewall six optional vulcanizer plates which could be repaired different place of tire. Firm and practical and operate conveniently. It is the advanced equipment to repair tire.



Tire Shoulder Vulcanization



Grease Filter



Tire Sidewall Vulcanization



Tire Tread Vulcanization



## Technique Parameter

Apply To	145-275
Voltage	220V/50Hz
Temperature	140-150℃
Power Of Heat Unit	2×0.25KW
Timer Scope	0-180 Minutes
Air Pressure Scope	8-10kg/cm <sup>2</sup>
Net Weight	47kg
Gross Weight	59kg
Appearance Color	Dark Red
Package Size	68×68×117cm

Item No.	Model No.	Commodity	Quantity
15610	BT-5000A	Air Operated Passenger Tire Vulcanizer	1 Set

- Air Operated Truck/Passenger Tire Vulcanizer designed specifically for 8.25--20 thru 12.00--20, 9R--12R and heat vulcanization of the repaired of the other tire. The function of the vulcanizer: thermostatically controlled, timer, pneumatic jacking system and pneumatic pressure device. Including seven vulcanizer plates, hand truck and Tire Spreader By Hand. Volt: 220V. Firm and practical and operate conveniently. It is the advanced equipment to repair tire.



Tire Sidewall Vulcanization



Tire Tread Vulcanization



Grease Filter

## Technique Parameter

Apply To	8.25-20/12.00-20(9R-12R)
Voltage	220V/50Hz
Temperature	140-150℃
Power Of Heat Unit	2×0.25KW
Timer Scope	0-180 Minutes
Air Pressure Scope	8-10kg/cm <sup>2</sup>
Net Weight	104kg
Gross Weight	128kg
Appearance Color	Dark Red
Package Size	114×50×84cm

Item No.	Model No.	Commodity	Quantity
15615	BT-6000A	Air Operated Truck Tire Vulcanizer	1 Set

# Spot Vulcanizer



● Spot passenger tire vulcanizer is designed specially for passenger car heat vulcanization of 145-275 tires. Including the devices of timer, automatically thermostatic controller, etc. and 6pcs optional vulcanization plates of sidewall, tread, shoulder, using 220V one-way voltage, It is convenient operation, ruggedization and practicality. and most economical and substantial tire repair equipment.



## Technique Parameter

Apply to	145-275
Voltage	220V/50Hz
Temperature	140-150℃
Power of Heat Unit	2×0.25KW
Time Scope	0~180Min
G.W.	14kg
N.W.	13kg
Package Size	56×30×28cm
Appearance Color	Red

Item No.	Model No.	Commodity	Weight
15602	BT-430P	Spot Passenger Tire Vulcanizer	10kg



Tire Tread Vulcanization



Tire Sidewall Vulcanization



Tire Shoulder Vulcanization



● Spot truck tire vulcanizer is designed specially for truck heat vulcanization 8.25-20 thru 12.00-20,9R-12R tires. Including the devices of timer, automatically thermostatic controller, etc., spot vulcanizer could be used for single-face and double-face vulcanization, and with 7pcs optional vulcanization plates of sidewall, tread, shoulder and spread-heat bag & spread-heat slice. Using 220V one-way voltage, this vulcanizer is convenient operation, ruggedization and practicality. It is the most economical and substantial tire repair equipment.

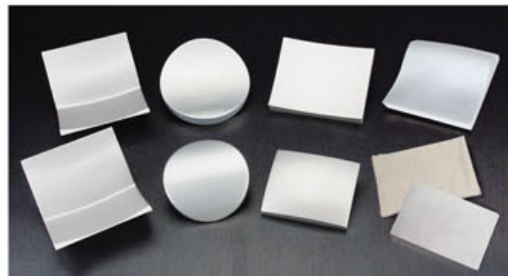

## Technique Parameter

Apply to	8.25-20/12.00-20/9R-12R
Voltage	220V/50Hz
Temperature	140-150℃
Power of Heat Unit	2×0.25KW
Time Scope	0~180Min
G.W.	25kg
N.W.	24kg
Package Size	70cm×36cm×30cm
Appearance Color	Red

Item No.	Model No.	Commodity	Weight
15604	BT-530P	Spot Truck Tire Vulcanizer	15kg



Tire Tread Vulcanization



Tire Sidewall Vulcanization



Tire Shoulder Vulcanization

# Tool Box & Tire Regroover

- The design of toolbox is graceful and practical. Not only enhance work efficiency and convenient operation, but also save working-space in maximum. The upper could display all kinds of tools and things one by one, and the bottom could stock spare repair patches.



Item No.	Commodity	Size
15761	Tool Box	262×403×1150mm

## TD-40RC Tire Regroover

- Recycle tires by carving different sizes and shapes with electrical contact and heat transfer. Split-type Adaptor makes the regrooving jobs more convenient and efficient. Turn on/off automatically when pushing and pressing, with overheat-protection design.



### Technique Parameter

Voltage	220V/50Hz
Power	0.24KW
G.W.	5kg
Package Size	210×130×330mm

### Regroover Blades

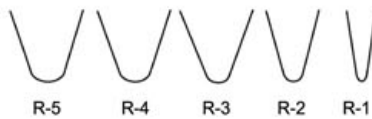

Item No.	Model No.	Commodity	Quantity
93209	TD-40RC	Tire Regroover	1set

Item No.	Model No.	Commodity	Width (mm)	Depth (mm)	Quantity
93211	R-1	Regroover Blade	2-3	9	20pcs/box
93212	R-2	Regroover Blade	3-5	10	20pcs/box
93213	R-3	Regroover Blade	5-9	12	20pcs/box
93214	R-4	Regroover Blade	7-11	13	20pcs/box
93215	R-5	Regroover Blade	9-14	14	20pcs/box
93216	W-1	Regroover Blade	2-3	9	20pcs/box
93217	W-2	Regroover Blade	4-6	11	20pcs/box
93218	W-3	Regroover Blade	6-9	13	20pcs/box
93219	W-4	Regroover Blade	8-11	14	20pcs/box
93220	W-5	Regroover Blade	10-14	14	20pcs/box

# Tire Brander

- Apply to brand trademark, serial no. and date etc on the tire. Arrange the matrix which will be branded in order and put into the "T" slotted (available for 10 matrixes to 1/2" Brander; 20 matrixes to 1/4" Brander) to preheating 10 minutes. And then it can reach the branding temperature it need. Aim at the area which will be branded on the tire to press down. It will have the branding depth over 2mm after 2-3 seconds.

## TB-1/4 Tire Brander



### Technique Parameter

Voltage	220V/50Hz
Highest Temperature	610°C
Power	0.45KW
Weight	2kg
Package Size	460×140×120mm

Item No.	Commodity	Quantity
15670	TB-1/4 Tire Brander	1set
15676	1/4"A-Z Letter Set	26pcs/set
15677	1/4"0-9 Number Set	10pcs/set

## TB-3/8 Tire Brander



### Technique Parameter

Voltage	220V/50Hz
Highest Temperature	610°C
Power	0.45KW
Weight	2kg
Package Size	460×140×120mm

Item No.	Commodity	Quantity
15671	TB-3/8 Tire Brander	1set
15678	3/8"A-Z Letter Set	26pcs/set
15679	3/8" 0-9 Number Set	10pcs/set

## TB-1/2 Tire Brander



### Technique Parameter

Voltage	220V/50Hz
Highest Temperature	610°C
Power	0.45KW
Weight	2kg
Package Size	460×140×120mm

Item No.	Commodity	Quantity
15672	TB-1/2 Tire Brander	1set
15674	1/2"A-Z Letter Set	26pcs/set
15675	1/2"0-9 Number Set	10pcs/set

# Extruder Gun

## BS-30HI

- Apply to fill rubber in part of tire retread industry during retreading truck/passenger tires.
- High precision, powerful motion and stable function



Item No.	Model No.	Commodity
15640	BS-30HI	Extruder Gun

## BS-40HN

- Apply to fill rubber in part of tire retread industry during retreading truck/passenger tires.
- High precision, powerful motion and stable function



Item No.	Model No.	Commodity
15642	BS-40HN	Extruder Gun

## BS-50HN

- Apply to fill rubber in part of tire retread industry during retreading engineering cars tires.
- High precision, powerful motion and stable function.



Item No.	Model No.	Commodity
15645	BS-50HN	Extruder Gun



### Technique Parameter

Voltage:220V/50Hz
Temperature Range:40-120℃
Power:0.35KW
Extruding Rubber Capacity:18kg/hr
Air Pressure:8-12kg/cm <sup>2</sup>
G.W.:5kg
N.W.:4.5kg
Package Size:480×140×190mm



### Technique Parameter

Voltage:220V/50Hz
Temperature Range:40-120℃
Power:0.35KW
Extruding Rubber Capacity:24kg/hr
Air Pressure:8-12kg/cm <sup>2</sup>
G.W.:6.5kg
N.W.:6kg
Package Size:480×140×190mm



### Technique Parameter

Voltage:220V/50Hz
Temperature Range:40-120℃
Power:0.35KW
Extruding Rubber Capacity:30kg/hr
Air Pressure:8-12kg/cm <sup>2</sup>
G.W.:6.5kg
N.W.:6kg
Package Size:480×140×190mm

# Air Grinder

- Apply to rubber buffing jobs during retreading tires, with low rotate-speed and big torque.
- 4000rpm



Item No.	Model No.	Commodity
15730	350S	Low Speed Air Grinder

- Apply to rubber buffing jobs during repairing tires. With low rotate-speed and big torque. The buffering speed of air grinder could avoid burning to the repair part of rubber.
- 2500rpm



Item No.	Model No.	Commodity
15734	330S	Low Speed Air Grinder

- Apply to cut framework material such as steel wire, etc. when repairing tires. With high rotate-speed and low torque.
- 20000rpm



Item No.	Model No.	Commodity
15736	405B	High Speed Air Grinder

- Apply to rubber buffing jobs during retreading tires. With big torque. The air grinder could fulfill tire retread factory with demand of pipelining task.
- 14000rpm



Item No.	Model No.	Commodity
15802	425B	Air Grinder

# Air-operated Impact Hammer, Air Vacuum Kit

- Apply to drill all kinds of curing-holes when repairing tires, with low rotate-speed, big torque. Using with all kinds of carbide cutters.
- 500rpm



Item No.	Model No.	Commodity
15812	620R	Low Speed Air Drill

- Apply to press tightly after patches affixed when repairing tires. Increasing the compactness between repair patch and tire.
- 3000times impact/min.



Item No.	Model No.	Commodity
15737	117A	Air-operated Impact Hammer

- Apply to suck rubber dust after grinding when repairing tires. With powerful suck-motion and high efficiency.



Item No.	Model No.	Commodity
15742	XC-54B	Air Vacuum Kit

- Work with Air Grinder and Buffing Rasps.



Item No.	Commodity	Spec.	Apply to
18204	Quick Adapter	56×3/8"-24	15010,15012,15014
18205	Quick Adapter	48×3/8"-24	15027,15029
18214	Quick Adapter	42×3/8"-24	15020,15017,15019
18211	Round-hole Quick Adapter	65×4.2mm	42395
18207	Round-hole Quick Adapter	65×6.5mm	42378,15018,15028
18208	Round-hole Quick Adapter	75×8mm	42379,42380,15038
18209	Round-hole Quick Adapter	80×10mm	42164
18210	Round-hole Quick Adapter	80×14mm	42168

# Aluminum Oxide Rasp & Carbide cutter

- Specialized in rubber buffing jobs when retreading tires. With quick heat spread, bear-abrasion and ruggedization. Lots of shapes are available to choose.
- Including balance wheel to avoid jumping when grinding.
- Grit:SSG-230/SSG-330/SSG-460

## Buffing Tool



## Contour Wheel



## Pencil Rasp



## Rotor Saw

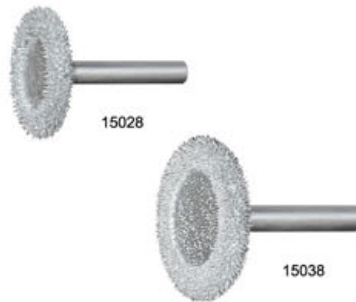

Item No.	Commodity	Spec.
15020	Aluminum Oxide Contour Wheel	45×20mm×3/8"-24
15010	Aluminum Oxide Contour Wheel	55×25mm×3/8"-24
15012	Aluminum Oxide Contour Wheel	65×25mm×3/8"AH
15014	Aluminum Oxide Contour Wheel	76×32mm×3/8"AH
15017	Aluminum Oxide Buffing Tool	50×5mm×3/8"-24
15019	Aluminum Oxide Buffing Tool	50×7mm×3/8"-24
15027	Aluminum Oxide Buffing Tool	50×10mm×3/8"-24
15029	Aluminum Oxide Buffing Tool	50×13mm×3/8"-24
15018	Aluminum Oxide Pencil Rasp	6/4×65mm
15021	Aluminum Oxide Pencil Rasp	6×65-40mm
15028	Aluminum Oxide Rotor Saw	35×3-6mm
15038	Aluminum Oxide Rotor Saw	50×3-8mm

- Apply to drill for the tire-cuts.
- This cutter is specially made from carbide, each angle of which is sharp-edged. It could be guaranteed to cut ruptured wire off in the tire-body at high efficiency.
- Max rotate-speed could not exceed 500rpm when using.

- Cut off ruptured wire in the tire-body.
- The highest rotate-speed is 20000rpm when using.



Item No.	Commodity	Spec.
42395	Carbide Cutter	75×4mm
42378	Carbide Cutter	80×6mm
42379	Carbide Cutter	100×8mm
42380	Carbide Cutter	110×10mm
42164	Carbide Cutter	125×13mm
42168	Carbide Cutter	140×18mm



Item No.	Commodity	Spec.
42381	Carbide Cutter	70×9mm
42383	Carbide Cutter	65×6mm
42374	Carbide Cutter	40×3mm

# Wire brush & Rubber Buffing Blade

## Wire Brush

- It is used for rubber buffing job
- The Max. speed can not exceed 4000rpm when using



Item No	Commodity	Specification
15329	3/8"Wire Brush	75x6mm
15330	1/2"Wire Brush	75x6mm
15335	Wire Brush	50x7mm3/8" AH
15336	Wire Brush	60x7mm3/8" AH
15337	Wire Brush	76x7mm3/8" AH

## Rubber Encased Wire Brush

- It is used for rubber buffing of steel wire on the tire.
- The Max. speed can not exceed 4000rpm when using



Item No	Commodity	Specification
15340	Rubber Encased Wire Brush	50x7mm3/8" AH
15341	Rubber Encased Wire Brush	60x7mm3/8" AH
15342	Rubber Encased Wire Brush	76x7mm3/8" AH

## Grinding Stone

- Polish & make buffing on the rubber of steel wire
- The Max. speed is 20000rpm when using.

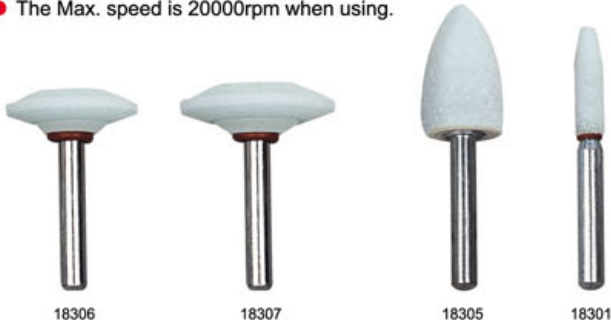

Item No	Model No	Commodity	Specification
18301	A15W	Grinding Pencil Stone	26x8-6mm
18305	A12W	Grinding Taper Stone	34x20-6mm
18306	A-37W	Grinding Mushroom Stone	32x10-6mm
18307	A-36W	Grinding Mushroom Stone	42x10-6mm

## Rubber Buffing Blade

- Apply to rubber buffing task when retreading tires.

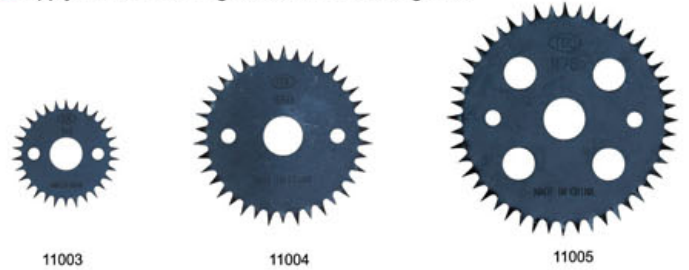

Item No.	Model No.	Commodity	Spec.	Quantity
11003	R45-6	Rubber Buffing Blade	45×0.7mm1/2"AH	6pcs/set
11004	R60-6	Rubber Buffing Blade	45×0.7mm1/2"AH	6pcs/set
11005	R75-6	Rubber Buffing Blade	45×0.7mm1/2"AH	6pcs/set



Item No.	Model No.	Commodity	Quantity
11007	R45	Rubber Buffing Wheel	1pce
11008	R60	Rubber Buffing Wheel	1pce
11009	R75	Rubber Buffing Wheel	1pce

## Rubber Buffing Blade

- It is used for assembly each piece blade together to be tire buffing rasp and fit it on the tire automatic buffing equipment, then make buffing on every type of tire tread with rubber surface smooth and even, long service life & good quality.

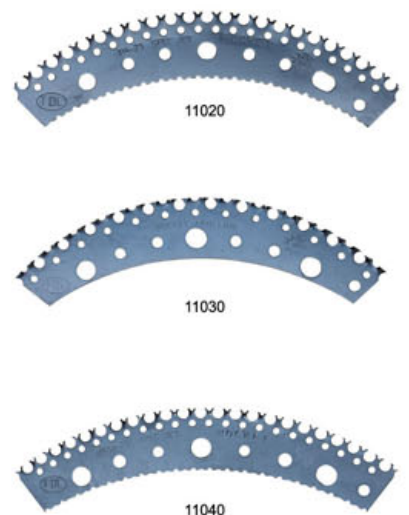

Item No.	Model No.	Commodity	Quantity
11020	R-4-25SJ	Rubber Buffing Blade	28pcs/set
11030	APOLLO II	Rubber Buffing Blade	28pcs/set
11040	R-115-25SJ	Rubber Buffing Blade	28pcs/set